

Model 4201 Accelerometer



Critically Gas Damped Accelerometer
Silicon MEMS Technology
Temperature Compensation
EMI/RFI Protection
Custom 8-Pole LP Filters



The **Model 4201** single axis accelerometer is designed with performance and reliability in mind. The rugged, gas damped accelerometer is ideally tailored for motorsport applications and road vehicle testing. The model 4201 features an 8-pole low-pass filter to ensure no high frequency engine noise will leak into the passband. A heavy-duty shielded cable and an EMI/RFI module protects the accelerometer from the harsh operating environment. Available in ranges from $\pm 6g$ to $\pm 50g$, the model 4201 will provide reliable measurements from $-40^{\circ}C$ to $+125^{\circ}C$.

FEATURES

- 8-16 Vdc Excitation
- Ranges up to $\pm 50 g$'s full scale
- Measures static & dynamic acceleration
- Over shock protection to $\pm 5,000 g$'s
- Operating range from -40 to $+125^{\circ}C$
- Built-in 8-pole low-pass filter
- EMI/RFI protection
- Transverse sensitivity $<1\%$ available

APPLICATIONS

- Motorsport Racing
- Engine Testing
- Road Vehicle Testing
- Low Frequency Measurements

dimensions

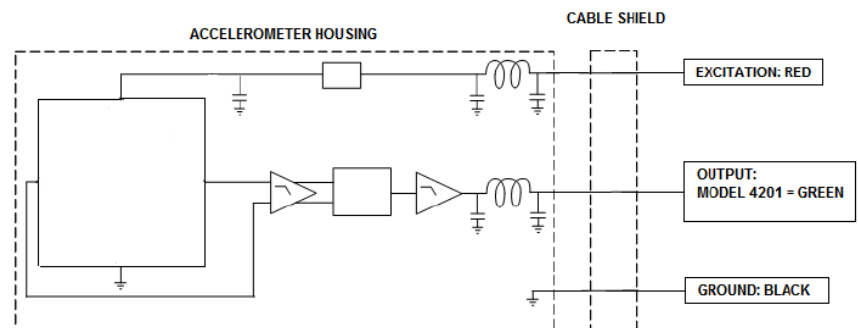
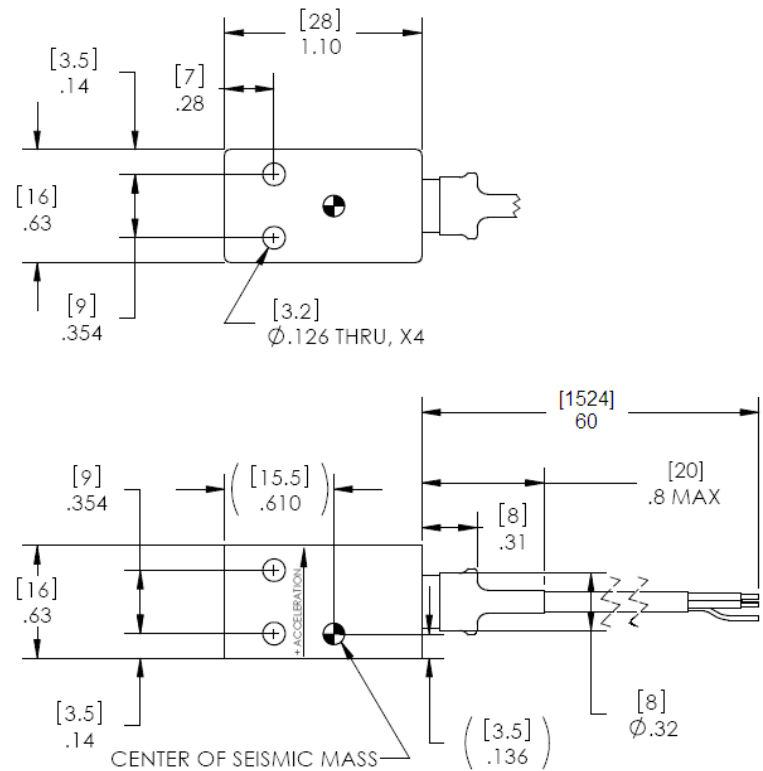

Model 4201 Accelerometer

performance specifications

All values are typical at +24°C, 100Hz and 12Vdc excitation unless otherwise stated. Measurement Specialties reserves the right to update and change these specifications without notice. Standard product parameters are described in PSC-1004 for Plug & Play DC Accelerometers.

Parameters

DYNAMIC

	±6	±10	±20	±30	±50	Notes
Range (g)	±6	±10	±20	±30	±50	
Sensitivity (mV/g)	333	200	100	67	40	±10%
-3dB Cutoff Frequency (Hz)	100 ±15	100 ±15	100 ±15	100 ±15	100 ±15	See alternate options below
Rolloff Above Cutoff Frequency (dB/dec)	-160	-160	-160	-160	-160	
Non-Linearity (%FSO)	±1.0	±1.0	±1.0	±1.0	±1.0	
Transverse Sensitivity (%)	<3	<3	<3	<3	<3	<1% Option
Damping Ratio	0.7	0.7	0.7	0.7	0.7	
Shock Limit (g)	5000	5000	5000	5000	5000	
Resolution (mg RMS)	0.5	0.5	1.0	1.0	3.0	Passband

ELECTRICAL

Zero Acceleration Output (V)	2.50 ±0.10					Single-ended
Excitation Voltage (Vdc)	8 to 16					
Excitation Current (mA)	<10					
Full Scale Output Voltage Swing (Vdc)	0.5 to 4.5					
Output Resistance (Ω)	<100					
Insulation Resistance (MΩ)	>100					@100Vdc
Turn On Time (msec)	<100					
Ground Isolation	Isolated from Mounting Surface					

ENVIRONMENTAL

Thermal Zero Shift (%FSO/°C)	±0.012
Thermal Sensitivity Shift (%/°C)	±0.020
Operating Temperature (°C)	-40 to 125
Storage Temperature (°C)	-40 to 125
Humidity	Epoxy Encapsulated, IP65

PHYSICAL

Case Material	Titanium
Cable	3x #24 AWG Conductors, ETFE Insulated, Braided Shield, Crosslinked ETFE Jacket
Weight (grams)	20 (cable not included)
Mounting	2x #4 or M3 Screws
Mounting Torque	6 lb-in (0.7 N-m)

Calibration supplied: CS-LFREQ-0010 NIST Traceable Amplitude Calibration from 1Hz to 100Hz

Optional accessories: 101 Three Channel DC Signal Conditioner Amplifier

ordering info

PART NUMBERING Model Number+Range+Filter Option

4201-XX-WW

Filter Option (G1 Standard)
Range (06 is ±6g, 10 is ±10g)

Dash Number Filter Cutoff Frequency
-G1 60 Hz
-G2 40 Hz
-G4 6 Hz
-G5 100 Hz

Example: 4201-10-G1
Model 4201, 10g, 60Hz Low-pass Filter

联系方式



深圳市亿为测控电子有限公司
Shenzhen Bill-Well Measurement & Control Electronics Co., Ltd.

广东省深圳市南山区创业路怡海广场东座2407 邮编：518000

电话：+86 755 2641 9890 传真：+86 755 2641 9680

电子邮箱：sales@bill-well.com